

Operational Instruction and Parts Manual

2SHE Series

Direct-Drive Shutter Fans



Fantech, Inc. and Systemair Mfg. certify that the ventilators shown herein are licensed to bear the AMCA Seal. The ratings shown are based on tests and procedures performed in accordance with AMCA Publication 211 and AMCA Publication 311 and comply with the requirements of the AMCA Certified Ratings Program.

United States





10048 Industrial Blvd., Lenexa, KS, 66215
Tel.: 800.747.1762 • Fax: 800.487.9915

Canada

50 Kanalfakt Way, Bouctouche, NB, E4S 3M5
Tel.: 800.565.3548 • Fax: 877.747.8116



fantech[®]
a systemair company

				
Note	Warning / Important note	Information	Technical information	Practical tip



Please read and save these instructions. Read carefully before attempting to assemble, install, operate or maintain the product described. Protect yourself and others by observing all safety information. Failure to comply with instructions could result in personal injury and/or property damage! Retain instructions for future reference.

Warning: Do not depend on any switch as sole means of disconnecting power when installing or servicing the fan. If the power disconnect is out-of-sight, lock it in the open position and tag to prevent application of power. Failure to do so may result in fatal electrical shock.

1. Follow all local electrical and safety codes in the United States and Canada, as well as the National Electrical Code (NEC) and the Occupational Safety and Health Act (OSHA) in the United States, and the Canadian Electric Code (CEC) in Canada.
2. Motor must be properly grounded by wiring with a grounded, metal-clad raceway system, by using a separate ground wire connected to the bare metal of the motor frame, or other suitable means.
3. Always disconnect power source before working on or near a motor or its connected load. If the power disconnect point is out-of-sight, lock it in the open position and tag to prevent unexpected application of power.

Caution: In United States, to reduce the risk of injury to persons, OSHA complying guards are required when fan is installed within 8 feet of floor, ground, or working level.

Caution: In Canada to reduce, the risk of injury to persons, CSA complying guards are required when fan is installed below 2.5 meters (8.2 feet) above floor or grade level.

Warning: Motor will restart without warning after protector trips.

Caution: Do not touch motor. It may be hot enough to cause injury.

4. Be careful when touching the exterior of an operating motor. It may be hot enough to be painful or cause injury. With modern motors, this condition is normal if operated at rated load and voltage; modern motors are built to operate at higher temperatures.
5. Protect the power cable from coming in contact with sharp objects.
6. Do not kink power cable and never allow the cable to come in contact with oil, grease, hot surfaces, or chemicals
7. Make certain that the power source conforms to the requirements of your equipment.

Description

Designed to ventilate stores, offices, factories, shops, farm buildings, etc. Efficient, easy-to install exhaust fan with automatic shutters. 7" to 36" diameter deep pitched propeller. Steel intake guard complies with United States OSHA Federal 1/2" max. opening requirement. Wire guard has charcoal gray metallic polyester finish to resist corrosion.

NOTE: These units are designed for wall mounting only.

Optional Accessories: Speed controllers, 3 amp model 5ACC03SC, 5 amp model 5ACC05SC, 6 amp model 5ACC06AC, and 10 amp model 5ACC10SC.

Unpacking

1. Inspect carefully for any damage that may have occurred during transit.
2. Before installing, rotate the propeller to be sure there are no obstructions which would interfere with proper operation. Adjust as required.

Dimensions

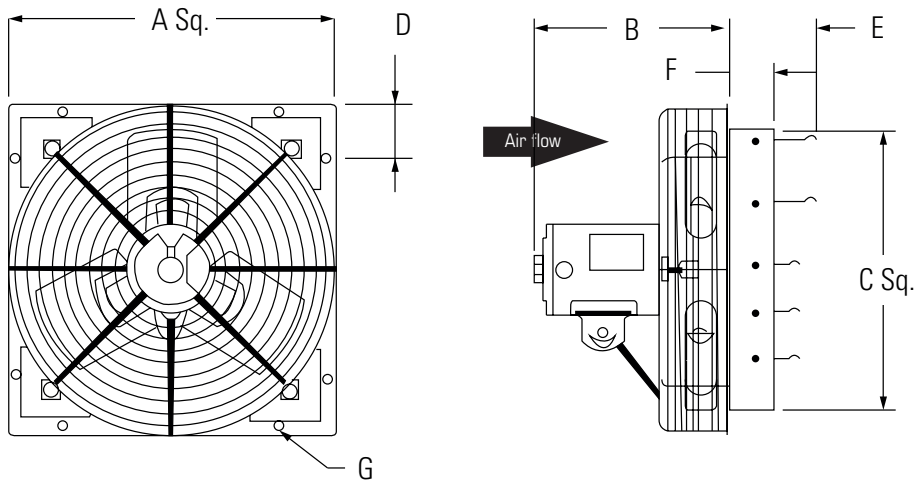

Table 1: Dimensional data

Model	A	B	C	D	E	F	G
2SHE 0721*	11 1/8	4 15/16	8 1/2	3 9/16	5 3/4	3	1/4 x 1/2
2SHE 1021*	13 1/8	5 9/16	10 1/2	10 1/2	5 3/4	3	1/4 x 1/2
2SHE 1221*	15 1/8	6	13	3 9/16	5 3/4	3	1/4 x 1/2
2SHE 1621*	19 1/8	6 13/16	17	10 1/2	5 3/4	3	1/4 x 1/2
2SHE 1871*	21 1/8	8 1/2	18 1/2	3 9/16	5 3/4	3	1/4 x 1/2
2SHE 20B1W*	23 1/8	10 3/4	21	10 1/2	5 3/4	3	1/4 x 1/2
2SHE 24B1W*	27 1/8	9 3/4	25	3 9/16	5 3/4	3	1/4 x 1/2
2SHE 30C1	33 1/8	13 1/8	31	10 1/2	5 3/4	3	1/4 x 1/2
2SHE 36D1	39 1/8	13 1/8	37	10 1/2	5 3/4	3	1/4 x 1/2

Dimensional information is in inches.

* - Speed Controllable

Installation

1. Frame in the wall opening with 2 x 4" lumber, to form a square. The opening should be 1/2" larger than the shutter frame (See Figure 1, dimension C).
2. Insert the fan (shutter end first) through the opening. Attach the flange to the frame using nails or screws (Not furnished).
3. Connect power supply to the motor using an approved wiring method. See preferred wiring diagram in Figure 2



The fan motor must be securely and adequately grounded to a suitable electrical ground such as a grounded water pipe or ground wire system!

4. Before activating the fan, double-check to ensure that there are no obstructions (framing, stud, shutter, etc.) which would interfere with proper fan operation.

Single Speed

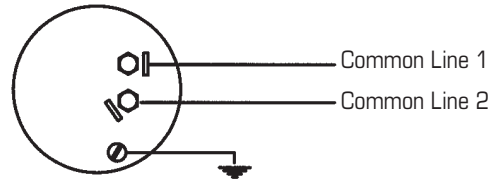

Single Speed

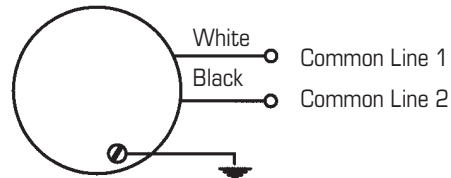

Figure 2 - Wiring Diagrams

Operation

1. Keep the area free of objects that could impede air flow on either the intake side or exhaust side of fan.
2. For proper exhausting, a window, door, or louver should be opened on the opposite side of the area to be ventilated.
3. Turn the fan ON, the shutter will open automatically. When the unit is turned OFF, the shutter will close.

Maintenance



Do not depend on any switch as sole means of disconnecting power when installing or servicing the fan. If the power disconnect is out-of-sight, lock it in the open position and tag to prevent application of power. Failure to do so may result in fatal electrical shock.

Minor and routine

1. Disconnect and lock out power source before servicing.
2. Lubricate the motor sleeve bearings every six months using S.A.E. 20 non-detergent oil.
3. Ball bearing motors are permanently lubricated at the factory. No further lubrication is necessary.
4. Periodically clean the propeller and motor of any excessive accumulation of dirt.

Parts and replacement

1. Refer to Figure 3 for correct positioning of parts.
2. Refer to "Repair Parts List" for ordering information.
3. Disconnect power before servicing.
4. Remove the four screws and nuts holding the guard to the venturi panel. Remove the guard/motor/propeller assembly.
5. Loosen the setscrew on propeller hub and remove the propeller.



Do not repair damaged propellers. They should be replaced with a properly balanced replacement.

6. Loosen the nuts holding motor on guard and remove motor. On split phase models, it is also necessary to loosen and remove bolt and nut holding yoke brace to motor yoke tabs.
7. Reassemble the unit in reverse order of disassembly.

For repair parts, call (800) 747-1762

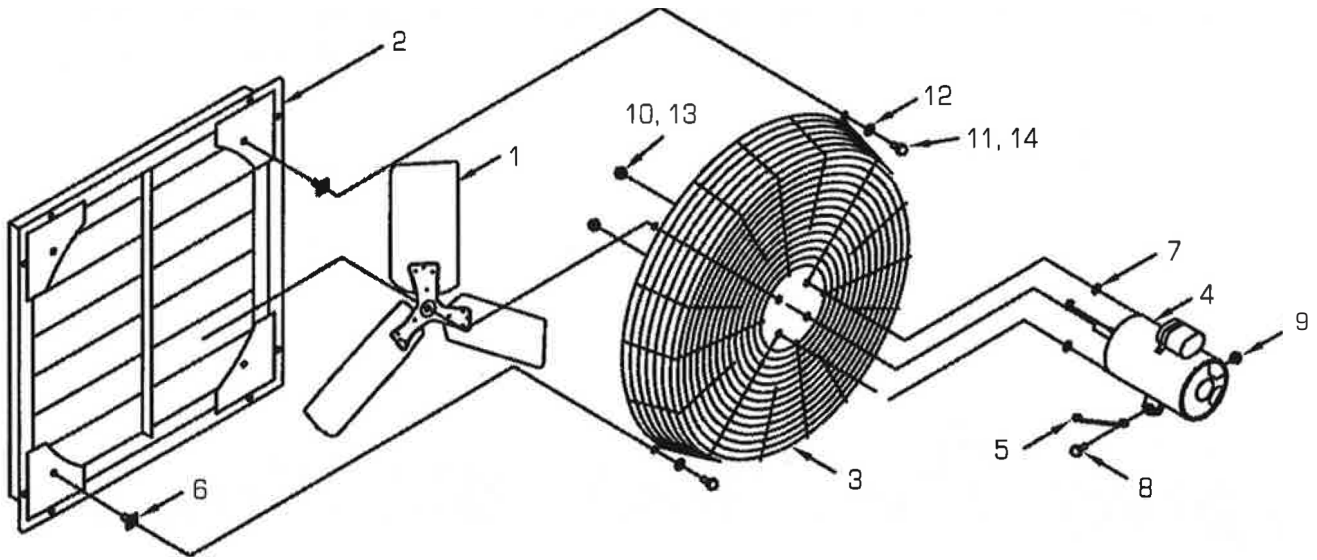

Figure 3. Repair parts illustration

Replacement Part List

Ref no.	Description	2SHE0721 thru 2SHE1871, Qty	2SHE20 thru 2SHE24, Qty	2SHE30 thru 2SHE36, Qty
1	Propeller	1	1	1
2	Shutter	1	1	1
3	Guard	1	1	1
4	Motor	1	1	1
5	Yoke brace	-	1	1
6	Grommet	-	4	-
7	10 x 3/4" Flat washer*	-	4	4
8	3/8-24 x 1" HHCS screw*	-	1	1
9	3/8-24 Spinlock nut*	-	1	1
10	#10-32 Spinlock nut*	-	4	4
11	#10-16 x 5/8" S.M. screw*	4	4	-
12	3/8" x 13/16" Flat washer*	-	1	-
13	#8-32 Spinlock nut*	4	-	-
14	#10-32 x 1.0 HWH screw	-	-	8

* Standard hardware item, available locally

Troubleshooting

Symptom	Possible causes	Corrective Action
Excessive noise	<ol style="list-style-type: none"> 1. Dry motor bearings 2. Loose propeller 3. Crooked or damaged propeller 	<ol style="list-style-type: none"> 1. Relubricate motor bearings 2. Tighten setscrews in hub 3. Replace propeller
Fan inoperative	<ol style="list-style-type: none"> 1. Blown fuse or open circuit breaker 2. Defective motor 3. Speed control set too low 	<ol style="list-style-type: none"> 1. Replace fuse or reset circuit breaker 2. Repair or replace motor 3. Increase speed with controller
Insufficient air flow	<ol style="list-style-type: none"> 1. Blocked intake or exhaust opening 2. Low voltage 3. Speed control set too low 	<ol style="list-style-type: none"> 1. Clear opening of obstruction or increase size of opening 2. Determine cause and correct 3. Increase speed with controller

Warranty

Fantech, Inc. warrants to the original purchaser that our products will be free from defects in material and workmanship for a period of one (1) year from the date of shipment. THIS IS OUR SOLE AND EXCLUSIVE PRODUCT WARRANTY AND IS IN LIEU OF AND EXCLUDES ALL OTHER WARRANTIES, EXPRESS OR IMPLIED, ARISING BY OPERATION OF LAW OR OTHERWISE, INCLUDING WITHOUT LIMITATION, MERCHANTABILITY AND FITNESS FOR A PARTICULAR PURPOSE WHETHER OR NOT THE PURPOSE OR USE HAS BEEN DISCLOSED TO US IN SPECIFICATIONS, DRAWINGS OR OTHERWISE, AND WHETHER OR NOT OUR PRODUCTS ARE SPECIFICALLY DESIGNED AND/OR MANUFACTURED BY US FOR PURCHASER'S USE OR PURPOSE.

This warranty does not cover any losses or damages due to misuse, accident, abuse, neglect, normal wear and tear, negligence (other than ours), unauthorized alteration, use beyond rated capacity, or improper installation, maintenance or application. This warranty shall be null and void to the extent that purchaser supplied incorrect information to us about the necessary product specifications or the environment in which the products were to be used, and our selection or design of the products for the purchaser was based in part on such information.

If within thirty (30) days after purchaser's discovery of any warranty defects within the warranty period, purchaser notifies us thereof in writing, we shall, at our option, repair, correct or replace F.O.B. point of manufacture, or refund the purchase price for, the products that we have

found to be defective. Failure by purchaser to give such written notice within the 30-day time period shall be deemed an absolute and unconditional waiver of purchaser's claim for such defects. Products repaired or replaced shall be covered by this warranty for the remainder of the original warranty period or ninety (90) days from the date of shipment, whichever is longer.

Warranty claims should be sent to Fantech, Inc.,
Attn: Quality Department, 10048 Industrial Blvd., Lenexa, KS 66215.
Included in the claim should be Order Number, Model Numbers, Serial Numbers and a detailed description of the issues.

Purchaser assumes all other responsibility for any loss, damage or injury to persons or property arising out of the use of our products, either alone or in combination with other products or components.

Limitation of Warranty and Liability

THE SOLE AND EXCLUSIVE REMEDY FOR BREACH OF ANY WARRANTY HEREUNDER SHALL BE LIMITED TO REPAIR, CORRECTION OR REPLACEMENT, OR REFUND OF THE PURCHASE PRICE UNDER THE PRECEDING PARAGRAPH ENTITLED "LIMITED WARRANTY". FANTECH VENTILATION PRODUCTS SHALL NOT BE LIABLE FOR DAMAGES CAUSED BY DELAY IN PERFORMANCE AND IN NO EVENT, REGARDLESS OF THE FORM OF THE CLAIM OR CAUSE OF ACTION, SHALL OUR LIABILITY TO PURCHASER AND/OR ITS CUSTOMERS EXCEED THE PRICE PAID BY PURCHASER FOR THE SPECIFIC PRODUCT PROVIDED BY US THAT GAUE RISE TO THE CLAIM OR CAUSE OF

ACTION. PURCHASER AGREES THAT IN NO EVENT SHALL OUR LIABILITY TO PURCHASER AND/OR ITS CUSTOMERS EXTEND TO INCLUDE INCIDENTAL, CONSEQUENTIAL OR PUNITIVE DAMAGES. The term "consequential damages" shall include, but not be limited to, loss of anticipated profits, business interruption, loss of use or revenue, cost of capital, or loss or damage to property or equipment. It is expressly understood that any technical advice furnished by us with respect to the use of our products is given without charge, and we assume no obligation or liability for the advice given, or results obtained, all such advice being given and accepted.

Warning

Fantech products are designed and manufactured to provide reliable performance, but they are not guaranteed to be 100% free from defects. Even reliable products will experience occasional failures and this possibility should be recognized by the user. If these products are

used in a life support ventilation system where failure could result in loss or injury, the user should provide adequate backup ventilation, supplementary natural ventilation, failure alarm system, or acknowledge willingness to accept the risk of such loss or injury.

Fantech reserves the right to make technical changes.
For updated documentation please refer to www.fantech.net

Fantech®